

FLOAT CALIBRATION

IS-199

FACTORY DEVELOPER _____
PRESET: FIXER _____

CHEMICAL MIXER

CHANGING FLOAT CALIBRATION

Should field conditions or a change in chemistry necessitate a change in specific gravity, adjustments can be made as follows:

TO INCREASE S.G. — Loosen cap/hex nut and slide adjustment bolt toward front of float. Retighten cap/hex nut.

TO DECREASE S.G. — Loosen cap/hex nut and slide adjustment bolt toward back of float. Retighten cap/hex nut.

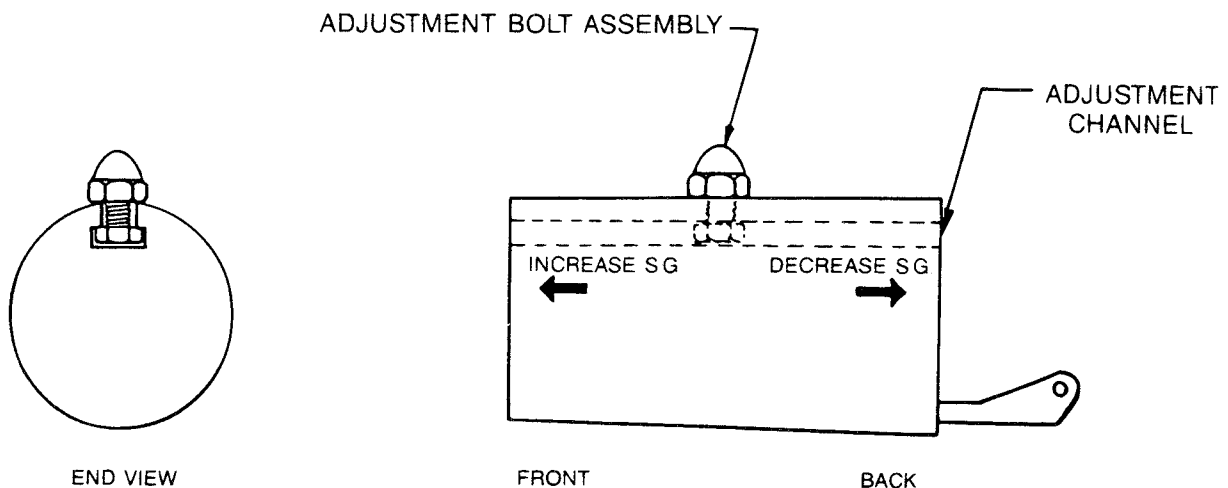

RANGES OF S.G. FLOATS

FLOAT TYPE A — 1.070 - 1.120

FLOAT TYPE B — 1.040 - 1.075

FLOAT TYPE C — 1.025 - 1.055

FOR MORE INFORMATION OR ASSISTANCE CALL WHITE MOUNTAIN IMAGING

PH: (603) 648-2124

FAX: (603) 648-2197

INSTALLATION INSTRUCTIONS

IS-199
CHEMICAL MIXER

1. Remove mixer from carton.
2. Place mixer at selected site — making sure it is level.
3. a. Install 3/8" hose adapter (included) in tank bulkhead.
b. Connect 1" I.D. Hose to 1" Overflow Elbow. Run hose to an open drain.

CAUTION: HOSE WITH A DIAMETER OF LESS THAN 1" I.D. SHOULD NOT BE USED.

4. a. Connect High-Pressure "Y" Hose (included) to Solenoids.
b. Connect the other end of "Y" to high pressure supply hose. A washer is provided.

**CAUTION: FRESH WATER SUPPLY MUST BE PROTECTED BY AN ANTI-SIPHON VALVE.
CONSULT LOCAL PLUMBING CODE FOR DETAILS.**

5. Unwrap Specific Gravity Floats. Developer and fixer floats are distinguished by a large "D" or "F" on the face of the float.

6. Holding float parallel to tank floor, engage float on one switch pin. Rotate gently until the second pin engages.

7. TEST: Plug in mixer to 120 V.A.C. grounded outlet. Lift float by hand and listen for the water Solenoid to activate. Lower float and listen for Solenoid to close.

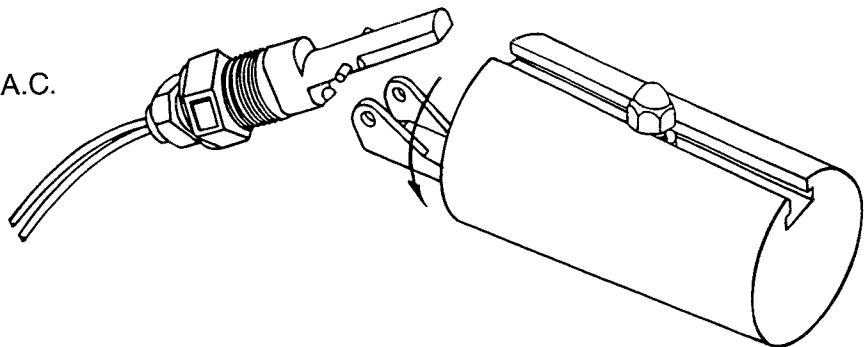

MIXER IS NOW READY FOR OPERATION

For Technical Assistance Call: (603) 648-2124.

OPERATING INSTRUCTIONS

IS-199

CHEMICAL MIXER

INITIAL START-UP

“Prime” mixer by adding approximately one gallon of water to both the Developer and the Fixer mixing tanks.

NOTE: THIS WILL ONLY BE NECESSARY FOR INITIAL START-UP.

INSTRUCTIONS FOR NORMAL OPERATION MAY NOW BE FOLLOWED.

TO MAKE A MIX

1. Make sure mixer is plugged in and water is turned on.
2. Remove caps from bottles and push down firmly on knives.
3. Check to see that all bottles have been pierced and are draining.
If not, press bottles down more firmly to pierce bottle seal.

THE MIXER WILL DO THE REST AUTOMATICALLY

LOW LEVEL WARNING SYSTEM

Low Level Indicator Lamp and Audible Alarm activate when the solution level falls to 2.0 Gallons or less.

Indicator Lamp on left is for Developer.

Indicator Lamp on right is for Fixer.

The Warning System will reset itself once a mix is started.

NOTE: IS-199 12.5 GALS — MIX CAN BE STARTED ANYTIME SOLUTION LEVEL IS BELOW “MIX LEVEL” LABEL.

IS-199 SPACE SAVER — MIX SHOULD BE STARTED ONLY WHEN LOW LEVEL WARNING SYSTEM INDICATES THE NEED FOR MORE CHEMICALS.

IS-199

REPLACEMENT PARTS LIST

PART NO.	DESCRIPTION
1901-D	Tank, P/E - Developer
1901-F	Tank, P/E- Fixer
1902	Component Cover
1903	Top Assembly
1904-D	Dev Template/Knife Assembly, Autex/Simon
1904-F	Fix Template/Knife Assembly, Standard
1905	Dev Template/Knife Assembly, Repack Dupont
1906-D	Dev Template/Knife Assembly, Kodak
1906-F	Fix Template/Knife Assembly, Kodak
1907-D	Dev Template/Knife Assembly, Agfa
1907-F	Fix Template/Knife Assembly, Agfa
1908	Retention Strap
1909	Knife - 38mm
1910	Knife - 28mm (special)
1911	Transformer
1911-EX	External Transformer
1912	Valve - Solenoid 24 Volt with Internal Flow Restrictor
1912-S	Inlet Screen for Cat #1912
1912-IFR	Internal Flow Restrictor and Retaining Ring
1912-RF	Resettable Fuse
1913	Audible Alarm
1914	Switch, Low Level
1915	Switch, Specific Gravity
1916	Float, S.G. Adjustable
1918	Wiring Harness
1919	Power Cord
1920	Lamp - 12 Volt Green
1921	Lamp - 12 Volt Red
1922	Lamp - 12 Volt Blue
1923	Spill Tray
1924	Floating Lid
1925	Water Inlet Pipe
1927	Replenisher Bulkhead, 3/8"
1928	Elbow - Overflow 1" w/Washer and Nut
1929	Hi-Pressure Y-Hose
1930	Flow Restrictor 3.0 GPM - External w/Adapter
1931	Template Cover Set
1933	Solenoid Coil (only)
1934	Fuse Holder & Fuse
1938	3/8" NPT x 3/8" Hose, 90° Adapter
1940-D	Dev Template/Knife Assembly, Dupont
1940-F	Fix Template/Knife Assembly, Dupont
1945-D	Dev Template/Knife Assembly, T ₂ Dev
1960	Terminal Strip

PRODUCT CHANGE

IS-199

SOLENOID VALVE COIL (Changed)
THERMOSTAT (Eliminated)
RESETTABLE FUSE (Added)

CHEMICAL MIXER

Since the first IS-199 mixers were built, a thermostatically controlled switch has been used to protect the solenoid valve from overheating if a mix is started but the water supply is off. In this case, the solenoid valve coil would be energized until the water needed to finish the mix was supplied, and the valve would be generating heat without a flow of water to cool it. The thermostat prevents this.

A minor change in the solenoid valve coil has made it possible to eliminate the thermostat and its mounting bracket. The new coil does not produce enough heat to benefit from a thermostat.

The new coil, which is dark red in color, is interchangeable with the old pink coil. Both will function properly in the mixer. It is acceptable to have two red coils, two pink coils, or one of each.

Resettable fuses (P/N 1912-RF) are now being used for circuit protection in the IS-199 mixer. Just like a traditional fuse, they will limit the current that can be used by the solenoid valve, providing protection to the transformer and specific gravity switch that are part of the same circuit. Unlike the usual fuse, they can be reset after a fault by removing power from the circuit. (Of course, the problem that caused the fault to occur must be corrected before restoring power or the fuse will trip again.)

It is not necessary to modify any older mixers presently in use. But if there is ever a need to replace a solenoid valve coil or a thermostat, adding the fuses then will improve the circuit protection. Detailed instructions can be found on the back of this page.

CONVERSION INSTRUCTIONS

IS-199

TO CHANGE FROM A THERMOSTAT TO A RESETTABLE FUSE

CHEMICAL MIXER

In all cases, do the following:

1. **Disconnect power to the mixer.**
2. Disconnect the black wire to the transformer from the thermostat. Be careful not to damage the female connector which will be reused.
3. Remove the other black wire to the thermostat from the terminal strip.
4. Connect the black transformer wire to the terminal strip in place of the one removed from the terminal strip.
5. Remove the thermostat with wire and mounting bracket from the solenoid valves. Discard these parts.
6. Insert resettable fuses between each solenoid valve coil and its white wire.

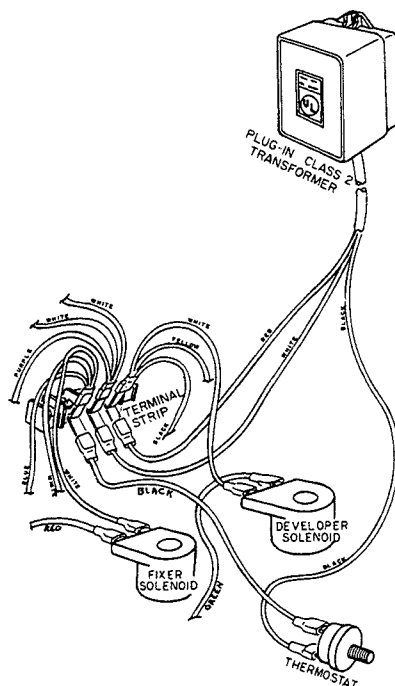

BEFORE CONVERSION

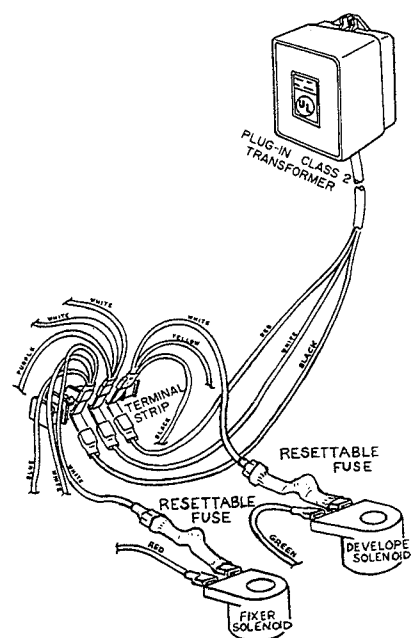

AFTER CONVERSION

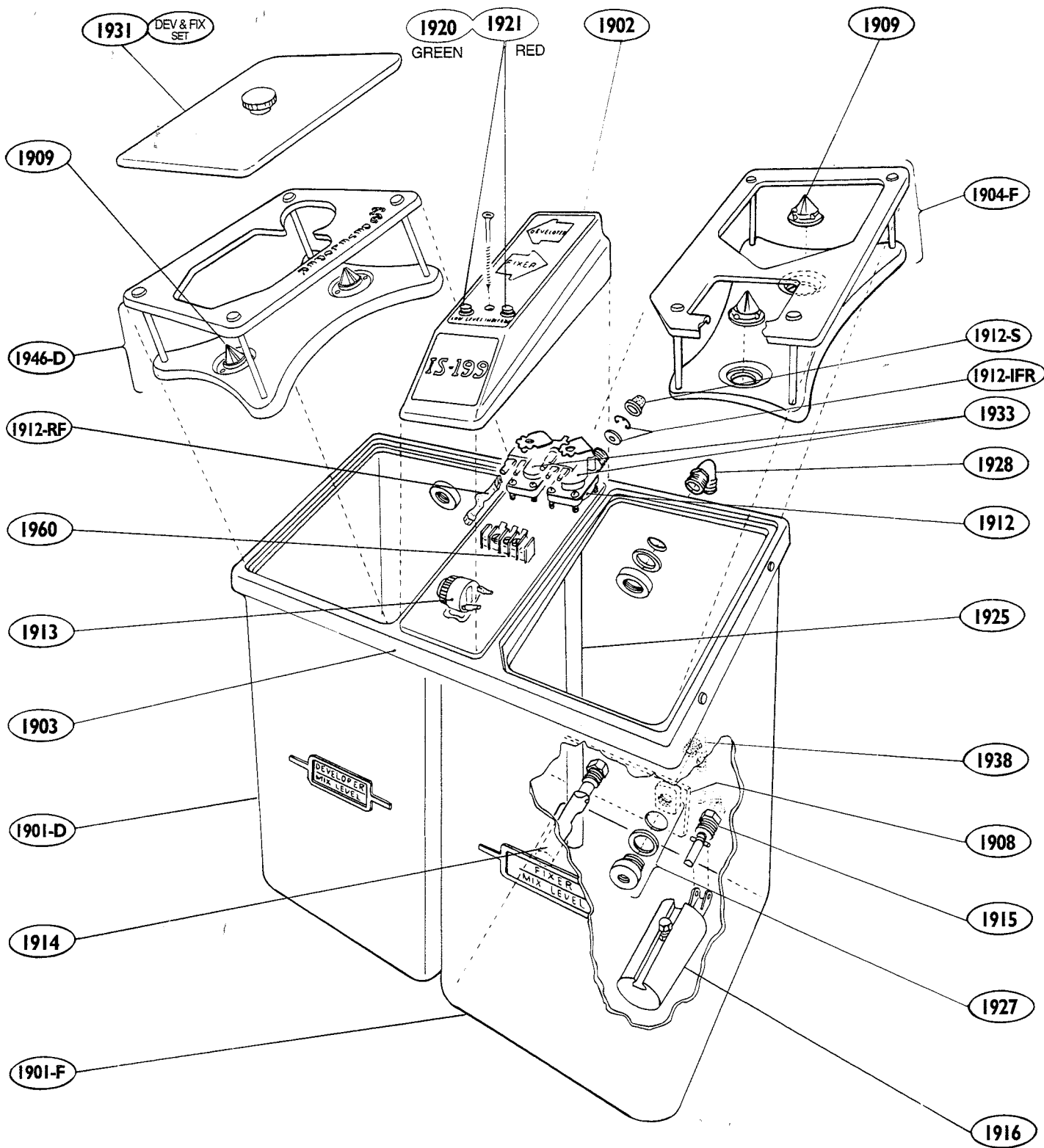

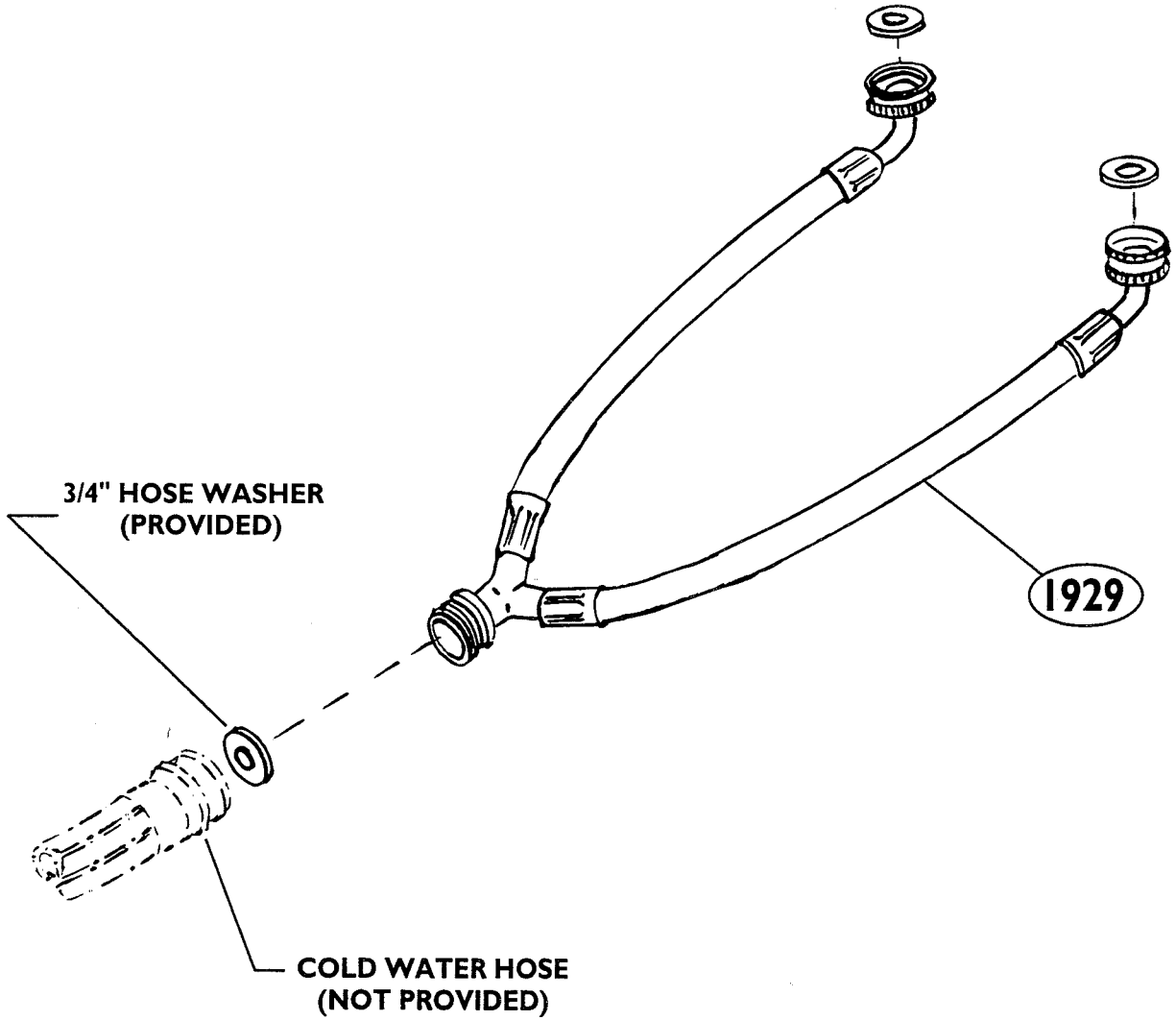
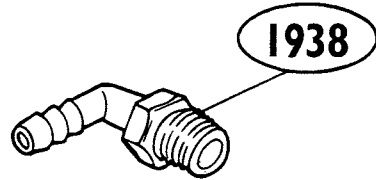
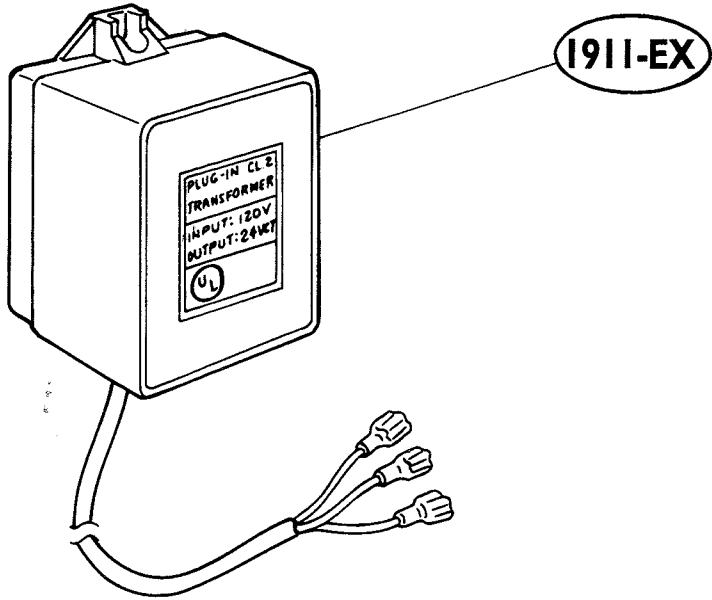

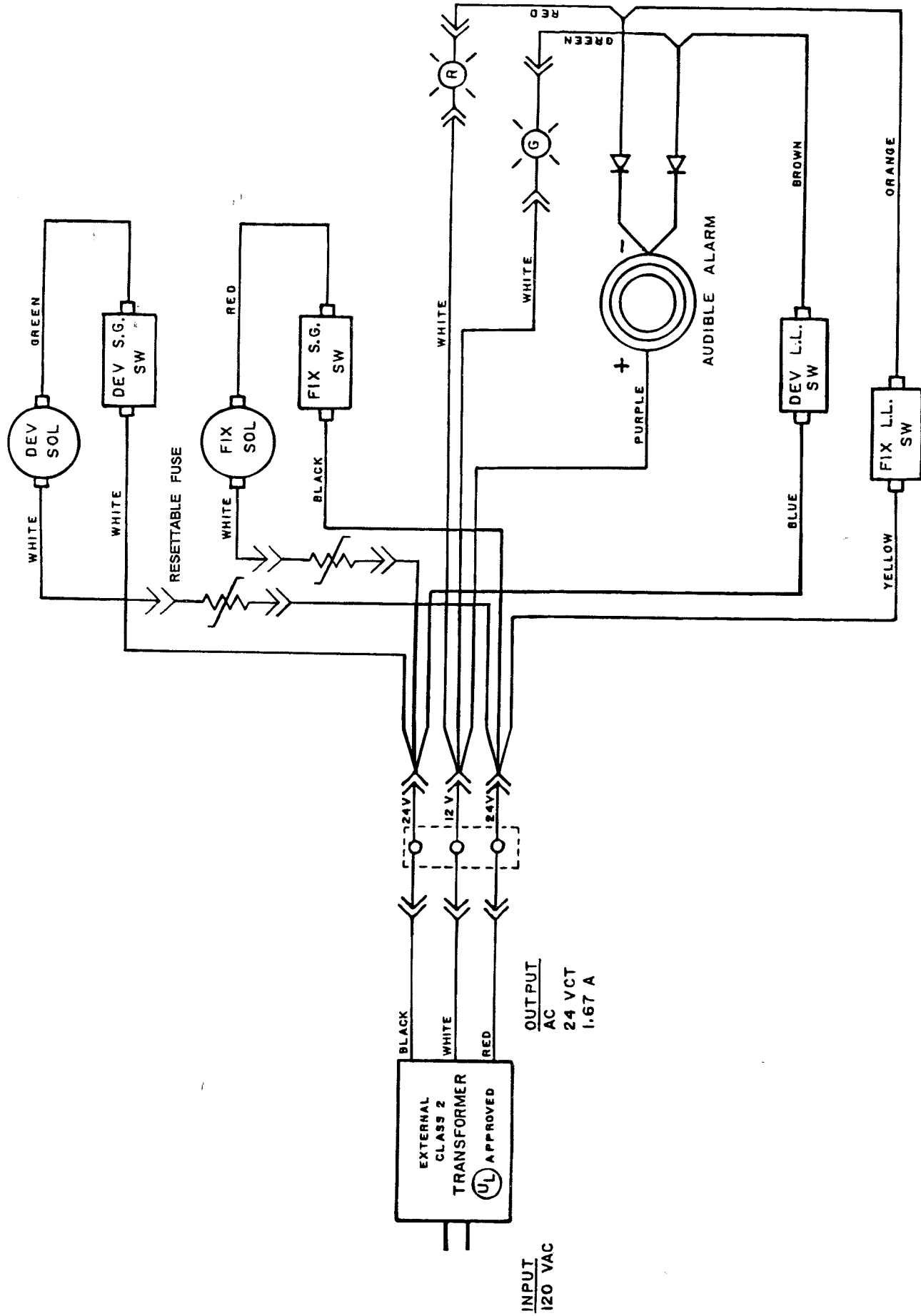

IS-199 CHEMICAL MIXER WITH EXTERNAL CLASS 2 TRANSFORMER

